

HXC SERIES
105°C High Ripple, Snap-in Terminal Type
◆ FEATURES

- Load Life : 105°C 2000 hours.
- Higher ripple current endurance than MXC series.
- RoHS compliance.

◆ SPECIFICATIONS

Items	Characteristics						
Category Temperature Range	-25~+105°C						
Rated Voltage Range	200, 400, 450V.DC						
Capacitance Tolerance	±20%(20°C,120Hz)						
Leakage Current(MAX)	$I = 3\sqrt{CV}$ (After 5 minutes application of rated voltage) $I = (\mu A)$ Leakage Current $V = (V)$ Rated Voltage $C = (\mu F)$ Rated Capacitance						
Dissipation Factor(MAX) (tanδ)	<table border="1"> <thead> <tr> <th>(V) Rated Voltage</th> <th>200~400</th> <th>450</th> </tr> </thead> <tbody> <tr> <td>tan δ</td> <td>0.15</td> <td>0.20</td> </tr> </tbody> </table> (20°C,120Hz)	(V) Rated Voltage	200~400	450	tan δ	0.15	0.20
(V) Rated Voltage	200~400	450					
tan δ	0.15	0.20					
Impedance Ratio(MAX)	<table border="1"> <thead> <tr> <th>(V) Rated Voltage</th> <th>200</th> <th>400~450</th> </tr> </thead> <tbody> <tr> <td>Z(-25°C)/Z(20°C)</td> <td>3</td> <td>8</td> </tr> </tbody> </table> (120Hz)	(V) Rated Voltage	200	400~450	Z(-25°C)/Z(20°C)	3	8
(V) Rated Voltage	200	400~450					
Z(-25°C)/Z(20°C)	3	8					
Endurance	After applying rated voltage with rated ripple current for 2000hrs at 105°C, the capacitors shall meet the following requirements. <table border="1"> <tbody> <tr> <td>Capacitance Change</td> <td>Within ±20% of the initial value.</td> </tr> <tr> <td>Dissipation Factor</td> <td>Not more than 200% of the specified value.</td> </tr> <tr> <td>Leakage Current</td> <td>Not more than the specified value.</td> </tr> </tbody> </table>	Capacitance Change	Within ±20% of the initial value.	Dissipation Factor	Not more than 200% of the specified value.	Leakage Current	Not more than the specified value.
Capacitance Change	Within ±20% of the initial value.						
Dissipation Factor	Not more than 200% of the specified value.						
Leakage Current	Not more than the specified value.						

◆ MULTIPLIER FOR RIPPLE CURRENT

Frequency coefficient

(Hz) Frequency		60(50)	120	500	1k	10k ≤
Coefficient	200WV	0.80	1.00	1.20	1.30	1.50
	400~450WV	0.80	1.00	1.20	1.25	1.40

◆ PART NUMBER

□□□	HXC	□□□□□	□	□□□	SN	D×L
Rated Voltage	Series	Rated Capacitance	Capacitance Tolerance	Option	Terminal Code	Case Size

◆ Option

	Code
PET Sleeve without plate	EFC
PVC Sleeve without plate	OOE
PVC Sleeve with plate	Blank

◆ DIMENSIONS

(mm)

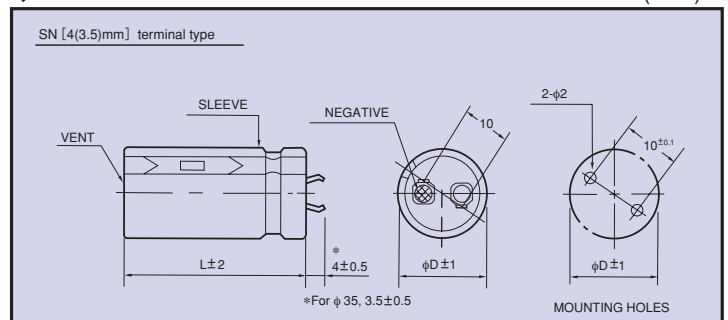



◆ STANDARD SIZE

Cap (μ F)	WV ϕ D	200							
		ϕ 22		ϕ 25		ϕ 30		ϕ 35	
270		22x25	1.64						
330		22x30	1.89						
390		22x35	2.14	25x25	1.99				
470		22x40	2.41	25x30	2.32	30x25	2.27		
560		22x45	2.71	25x35	2.63	30x25	2.43		
680		22x50	3.06	25x35	2.81	30x30	2.82		
820				25x45	3.32	30x30	2.94	35x25	2.56
1000				25x50	3.72	30x35	3.36	35x30	3.07
1200						30x40	3.78	35x35	3.57
1500						30x50	4.48	35x40	4.01
1800								35x45	4.44
2200								35x50	4.90

Cap (μ F)	WV ϕ D	400							
		ϕ 22		ϕ 25		ϕ 30		ϕ 35	
82		22x30	0.81						
100		22x35	0.99	25x25	0.99				
120		22x40	1.19	25x30	1.19				
150		22x45	1.43	25x35	1.43	30x25	1.41		
180		22x50	1.60	25x40	1.61	30x30	1.61		
220				25x45	1.83	30x35	1.84		
270				25x50	2.06	30x40	2.10	35x30	2.00
330						30x45	2.36	35x35	2.29
390						30x50	2.62	35x40	2.56
470								35x45	2.86
560								35x50	3.15

Cap (μ F)	WV ϕ D	450							
		ϕ 22		ϕ 25		ϕ 30		ϕ 35	
68		22x30	0.67						
82		22x35	0.81	25x25	0.81				
100		22x40	0.99	25x30	0.99				
120		22x45	1.19	25x35	1.19	30x25	1.19		
150				25x40	1.49	30x30	1.49	35x25	1.49
180				25x45	1.68	30x35	1.70	35x25	1.61
220				25x50	1.89	30x40	1.92	35x30	1.85
270						30x45	2.18	35x35	2.12
330						30x50	2.45	35x40	2.41
390								35x45	2.67
470								35x50	2.97

↑ Ripple Current (A r.m.s./120Hz, 105°C)
 ↑ Case Size ϕ D x L (mm)