

AXF SERIES
105°C Low profile, Snap-in Terminal Type
◆ FEATURES

- Load Life : 105°C 3000 hours, with 20mm height.
- Smaller size with higher ripple current endurance than MXF series.
- RoHS compliance.

◆ SPECIFICATIONS

Items	Characteristics																							
Category Temperature Range	-40~+105°C	-25~+105°C																						
Rated Voltage Range	10~100V.DC	160~450V.DC																						
Capacitance Tolerance	±20%(20°C,120Hz)																							
Leakage Current(MAX)	$I = 3\sqrt{CV}$ (After 5 minutes application of rated voltage) $I = (\mu A)$ Leakage Current $V = (V)$ Rated Voltage $C = (\mu F)$ Rated Capacitance																							
Dissipation Factor(MAX)‡ (tanδ)	<table border="1"> <thead> <tr> <th>(V) Rated Voltage</th> <th>10</th> <th>16</th> <th>25</th> <th>35</th> <th>50</th> <th>63</th> <th>80</th> <th>100</th> <th>160~400</th> <th>420~450</th> </tr> </thead> <tbody> <tr> <td>tan δ</td> <td>0.55</td> <td>0.50</td> <td>0.45</td> <td>0.40</td> <td>0.35</td> <td>0.30</td> <td>0.25</td> <td>0.20</td> <td>0.15</td> <td>0.20</td> </tr> </tbody> </table> (20°C,120Hz)		(V) Rated Voltage	10	16	25	35	50	63	80	100	160~400	420~450	tan δ	0.55	0.50	0.45	0.40	0.35	0.30	0.25	0.20	0.15	0.20
(V) Rated Voltage	10	16	25	35	50	63	80	100	160~400	420~450														
tan δ	0.55	0.50	0.45	0.40	0.35	0.30	0.25	0.20	0.15	0.20														
Impedance Ratio(MAX)	<table border="1"> <thead> <tr> <th>(V) Rated Voltage</th> <th>10~100</th> <th>160~250</th> <th>315~450</th> </tr> </thead> <tbody> <tr> <td>Z(-25°C)/Z(20°C)</td> <td>3</td> <td>3</td> <td>8</td> </tr> <tr> <td>Z(-40°C)/Z(20°C)</td> <td>12</td> <td>-</td> <td>-</td> </tr> </tbody> </table> (120Hz)		(V) Rated Voltage	10~100	160~250	315~450	Z(-25°C)/Z(20°C)	3	3	8	Z(-40°C)/Z(20°C)	12	-	-										
(V) Rated Voltage	10~100	160~250	315~450																					
Z(-25°C)/Z(20°C)	3	3	8																					
Z(-40°C)/Z(20°C)	12	-	-																					
Endurance	After applying rated voltage with rated ripple current for 3000hrs at 105°C, the capacitors shall meet the following requirements. <table border="1"> <tbody> <tr> <td>Capacitance Change</td> <td>Within ±20% of the initial value.</td> </tr> <tr> <td>Dissipation Factor</td> <td>Not more than 200% of the specified value.</td> </tr> <tr> <td>Leakage Current</td> <td>Not more than the specified value.</td> </tr> </tbody> </table>		Capacitance Change	Within ±20% of the initial value.	Dissipation Factor	Not more than 200% of the specified value.	Leakage Current	Not more than the specified value.																
Capacitance Change	Within ±20% of the initial value.																							
Dissipation Factor	Not more than 200% of the specified value.																							
Leakage Current	Not more than the specified value.																							

◆ MULTIPLIER FOR RIPPLE CURRENT

Frequency coefficient

(Hz) Frequency		60(50)	120	500	1k	10k±
Coefficient	10~100WV	0.90	1.00	1.05	1.10	1.15
	160~250WV	0.80	1.00	1.20	1.30	1.50
	315~450WV	0.80	1.00	1.20	1.25	1.40

◆ PART NUMBER

□□□	AXF	□□□□□	□	□□□	SN	D×L
Rated Voltage	Series	Rated Capacitance	Capacitance Tolerance	Option	Terminal Code	Case Size

◆ Option

	Code
PET Sleeve without plate	EFC
PVC Sleeve without plate	OOE
PVC Sleeve with plate	Blank

◆ DIMENSIONS

(mm)

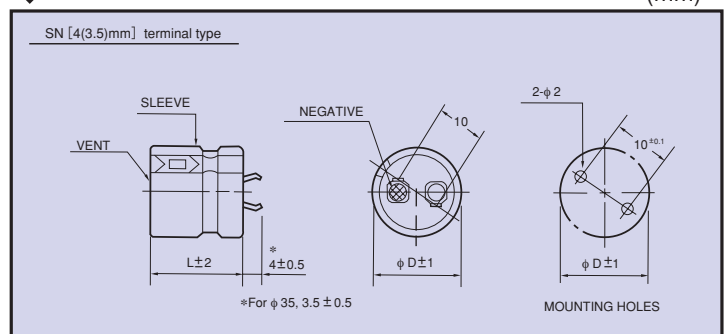



◆ STANDARD SIZE

Cap(μF) \ WV	10	16	25	35	50	63	80	100
330								20×20 0.60
390								20×20 0.71
470							20×20 0.65	22×20 0.78
560							20×20 0.70	25×20 0.95
680						20×20 0.83	22×20 0.84	25×20 1.09
820						22×20 0.99	25×20 1.04	30×20 1.32
1000					20×20 0.87	22×20 1.10	25×20 1.19	
1200					22×20 1.02	25×20 1.20	30×20 1.44	
1500				20×20 0.80	25×20 1.15	30×20 1.47		
1800				22×20 0.94	25×20 1.34	30×20 1.52		
2200			20×20 0.98	22×20 1.04	30×20 1.60			
2700			22×20 1.08	25×20 1.29				
3300		20×20 1.06	22×20 1.29	30×20 1.45				
3900		20×20 1.25	25×20 1.58					
4700	20×20 0.98	22×20 1.38	25×20 1.61					
5600	20×20 1.16	25×20 1.68						
6800	22×20 1.31	25×20 1.80						
8200	25×20 1.59							
10000	25×20 1.77							

Cap(μF) \ WV	160	180	200	220	250	315	350	385
39								20×20 0.35
47							20×20 0.38	20×20 0.38
56						20×20 0.41	20×20 0.40	22×20 0.42
68						22×20 0.48	22×20 0.45	25×20 0.50
82						22×20 0.51	25×20 0.54	25×20 0.52
100					20×20 0.59	25×20 0.57	25×20 0.57	30×20 0.61
120			20×20 0.63	20×20 0.60	22×20 0.65	30×20 0.65	30×20 0.65	30×20 0.64
150		20×20 0.66	20×20 0.66	22×20 0.70	25×20 0.74	30×20 0.70	35×20 0.78	35×20 0.80
180	20×20 0.69	22×20 0.80	22×20 0.80	25×20 0.80	25×20 0.77	35×20 0.85	35×20 0.85	
220	22×20 0.81	25×20 0.90	25×20 0.87	25×20 0.85	30×20 0.95	35×20 0.90		
270	25×20 0.98	25×20 0.95	25×20 0.95	30×20 1.02	30×20 1.00			
330	25×20 1.02	30×20 1.15	30×20 1.15	30×20 1.12	35×20 1.16			
390	30×20 1.25	30×20 1.20	30×20 1.20	35×20 1.25				
470	30×20 1.30	35×20 1.36	35×20 1.41					
560	35×20 1.46	35×20 1.43						
680	35×20 1.51							

Cap(μF) \ WV	400	420	450
27			20×20 0.26
33		20×20 0.30	20×20 0.30
39	20×20 0.34	20×20 0.34	22×20 0.36
47	22×20 0.39	22×20 0.38	25×20 0.41
56	22×20 0.40	25×20 0.45	25×20 0.43
68	25×20 0.49	25×20 0.48	30×20 0.50
82	30×20 0.55	30×20 0.53	30×20 0.53
100	30×20 0.60	30×20 0.58	35×20 0.61
120	35×20 0.75	35×20 0.70	
150	35×20 0.80		

↑ Ripple Current (A r.m.s./120Hz, 105°C)
 ↑ Case Size φ D×L(mm)